

### Finishing APA Rated Siding

**TIP 1**

Pad corners with rags

Lay two 2x4s on top of stack

Stretch film over stack and secure to tie-down stakes

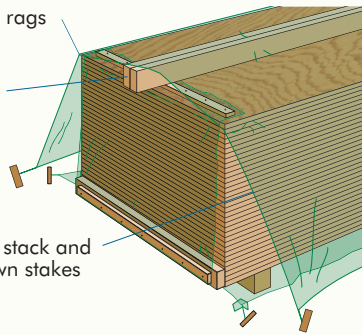

In addition to structural stability and durability, APA Rated Siding offers the aesthetic appeal of wood. To keep siding looking good and performing well, follow the finishing tips below. Proper finishing protects siding from the weather, reduces maintenance and promotes long-lasting performance. For specific recommendations on finishing APA trademarked products, consult your siding manufacturer or supplier.

**Tip 1: Protect siding on the job site.** Put siding indoors, out of the weather, if possible. If space is not available inside, loosen the straps, store the bundles off the ground on stringers, and cover them with plastic. Be sure to allow ample space for air circulation. See *APA Builder Tips: Storage and Handling of APA Trademarked Panels*, Form U450.

**TIP 2**

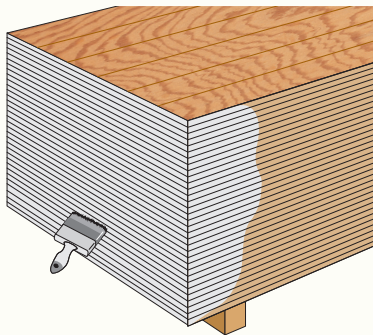

**Tip 2: Seal panel edges.** Prior to installation, seal all siding edges with a paintable water-repellent preservative if the siding is to be stained, or primer if the siding is to be painted. This will help minimize sudden changes in panel moisture content due to weather fluctuations. Also seal all edges cut during installation.

**TIPS 3-7**



**Tip 3: Apply first coat of finish ASAP, preferably within 2 weeks of installation.** Weather can cause surface damage to unprotected wood within 4 weeks of exposure and adversely affect the performance of subsequently applied finishes. Preprimed products should be top-coated within 60 to 90 days of installation. Check the siding manufacturer's recommendations.

**Tip 4: Select high quality stain or paint suitable for your siding grade.** The best protection for wood siding is an all-acrylic latex house paint system composed of primer and topcoat. Solid-color stain, either latex or oil-based, provides good protection, and semitransparent stains give minimum protection to your panels. APA does not recommend oil-based house paints or latex semitransparent stains on APA Rated Sidings. Clear finishes also are not recommended on APA Rated Sidings exposed outdoors. See Table 1 for the best finish for your siding product.

**Tip 5: Apply finish to a clean surface.** Remove all dirt, mildew and loose wood particles from the siding surface before applying finish. This will ensure that your finish goes on evenly and stays on.

**Tip 6: Apply finish in good weather.** Siding must be dry for oil-based finishes, but may be slightly damp for latex finishes. Do not apply finishes to extremely hot or cold surfaces.

**Tip 7: Work finish into siding surface.** The first coat should either be brush-applied or sprayed and back-brushed while the finish is still wet. This is essential for textured surfaces, such as rough-sawn. Brushing helps work the finish into the siding, therefore providing better protection to the siding surface and optimum finish adhesion.

**Tip 8: Always follow manufacturer’s recommendations.** Follow manufacturer’s suggestions as to the best finish for your siding product.

TABLE 1

**RECOMMENDED FINISHES**

Finish	Panel Product					
	303-OC, -OL, -NR, -SR	303-6-W, -6-S, -6-S/W	303-18-W, -18-S, -18-S/W	303-30-W, -30-S, -30-S/W	COM-PLY	Overlaid OSB
<b>Semitransparent Stain Oil</b>	-OC <sup>(b)</sup> , -OL Not recommended, -NR <sup>(b)</sup> , -SR <sup>(c)</sup>	-6-W <sup>(b)</sup> , -6-S <sup>(c)</sup> , -6-S/W <sup>(c)</sup>	(c)	(c)	Not recommended	Not recommended
<b>Solid-Color Stain Oil or Latex<sup>(a)</sup></b>	-OC <sup>(b)</sup> , -OL <sup>(d)</sup> , -NR <sup>(e)</sup> , -SR <sup>(e)</sup>	(b)	(b)	(b)	(d)	Not recommended
<b>House Paint Acrylic Latex</b>						
Minimum 1 Primer	(b)	(b)	(b)	(b)	(b)	(b)
Plus 1 Top Coat						

- Key**
- (a) Except for overlaid siding, use a stain-blocking primer with light-colored latex stains since the wood extractives may cause a discoloration of the finish.
  - (b) Recommended with provisions given in *APA Product Guide: Performance Rated Siding*, Form No. E300.
  - (c) These face grades should not be finished with semitransparent stains unless specifically recommended by the siding manufacturer.
  - (d) Some siding manufacturers recommend only acrylic latex formulations. Consult the manufacturer’s recommendations.
  - (e) Only latex formulations are recommended.

We have field representatives in many major U.S. cities and in Canada who can help answer questions involving APA trademarked products. For additional assistance in specifying engineered wood products, contact us:

**APA HEADQUARTERS:** 7011 So. 19th St. ■ Tacoma, Washington 98466 ■ (253) 565-6600 ■ Fax: (253) 565-7265

**APA PRODUCT SUPPORT HELP DESK:** (253) 620-7400 ■ E-mail: help@apawood.org

[www.apawood.org](http://www.apawood.org)

Form No. Q350F

Revised May 2013

**DISCLAIMER:** The information contained herein is based on APA – The Engineered Wood Association’s continuing programs of laboratory testing, product research, and comprehensive field experience. Neither APA, nor its members make any warranty, expressed or implied, or assume any legal liability or responsibility for the use, application of, and/or reference to opinions, findings, conclusions, or recommendations included in this publication. Consult your local jurisdiction or design professional to assure compliance with code, construction, and performance requirements. Because APA has no control over quality of workmanship or the conditions under which engineered wood products are used, it cannot accept responsibility for product performance or designs as actually constructed.



REPRESENTING THE ENGINEERED WOOD INDUSTRY